

# HISTORY OF COMPUTER SCIENCE

Gordana Dodig - Crnkovic,  
e-mail: [gordana.dodig-crnkovic@mdh.se](mailto:gordana.dodig-crnkovic@mdh.se)

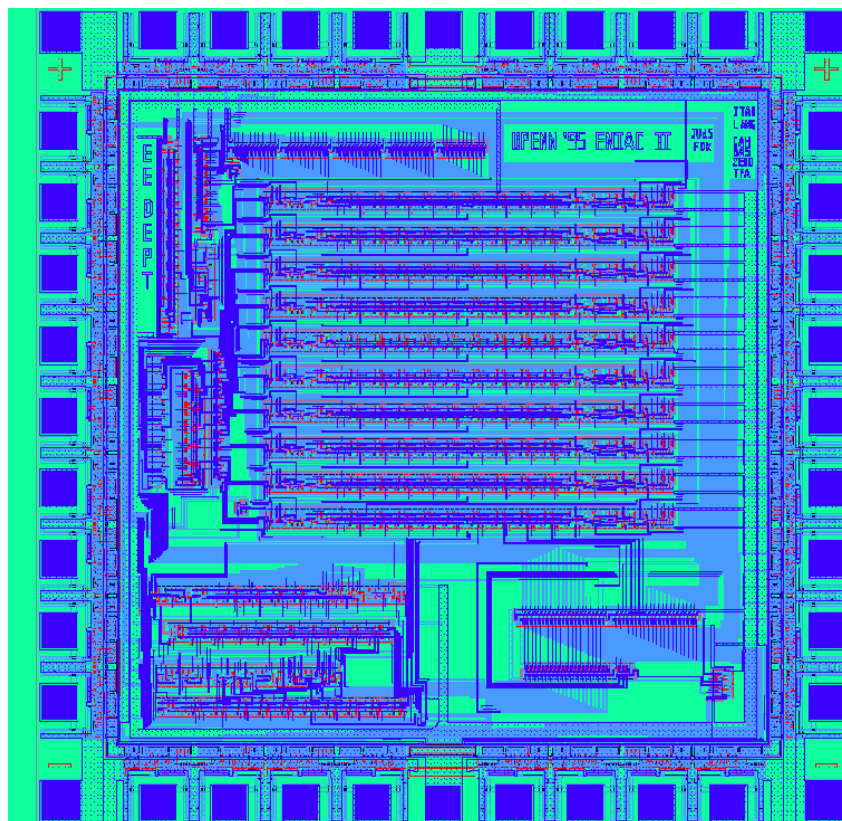

A group of students at the Department of Electrical Engineering University of Pennsylvania have designed "ENIAC(TM)-on-a-Chip", under supervision of Professor J. Van der Spiegel, in collaboration with Dr. F. Ketterer. This was done as part of Eniac's 50th Anniversary Celebration. They have integrated the whole "ENIAC" on a 7.44 by 5.29 sq. mm chip using a 0.5 micrometer CMOS technology.

## Table of Contents

INTRODUCTION: MILESTONES IN THE DEVELOPMENT OF COMPUTERS .....	4
Before 1900: First Computing Devices .....	4
1900 – 1939 The Rise of Mathematics .....	6
1940's: First Electronic Digital Computer .....	6
1950's .....	7
1960's .....	7
1970's .....	8
1980's .....	8
1990's and Beyond.....	9
1    LEIBNIZ: LOGICAL CALCULUS .....	10
Calculus Ratiocinator .....	12
Language and Mind .....	13
2    BOOLE: LOGIC AS ALGEBRA.....	15
Bool's Algebra of Logic .....	16
3    FREGE: MATEMATICS AS LOGIC.....	19
Frege's Advances in Logic .....	20
The Predicate Calculus .....	20
The Analysis of Atomic Sentences and Quantifier Phrases .....	20
Proof .....	21
4    CANTOR: INFINITY .....	22
5    HILBERT: PROGRAM FOR MATHEMATICS .....	24
Hilbert's Program .....	27
6    GÖDEL: END OF HILBERTS PROGRAM .....	28
7    TURING: UNIVERSAL AUTOMATON.....	30
The Turing Machine .....	32
8    VON NEUMAN: COMPUTER .....	35
APPENDIX 1 .....	38
Charles Babbage .....	38
Augusta Ada King, Countess of Lovelace.....	41
APPENDIX 2 .....	42
Russels paradox .....	42

## INTRODUCTION: MILESTONES IN THE DEVELOPMENT OF COMPUTERS

### Before 1900: First Computing Devices

A number of early cultures have developed mechanical computing devices. For example, the abacus probably existed in Babylonia about 3000 B.C. The Chinese abacus is an excellent example, remaining unsurpassed in speed and accuracy of operation well into this century. This dominance of several thousand years is unequalled for a specific type of computer. Certainly our nowadays computers are unlikely to equal it. The classical abacus was called *suan pan* by the Chinese- which meant “counting” or “reckoning” board. Small beads of bone or ivory were strung on parallel bamboo runners and set into a rectangular frame. Each row of these beads corresponded to one column of written numbers. It was an incredibly powerful tool for rapidly adding and subtracting large numbers.

The ancient Greeks developed some very sophisticated analog machines. In 1901, an ancient Greek shipwreck was discovered off the island of Antikythera. Inside was a salt-encrusted device (now called the Antikythera mechanism) that consisted of rusted metal gears and pointers. When this c. 80 B.C. device was reconstructed, it produced a mechanism for predicting the motions of the stars and planets.

The Romans used their hands to calculate. Because of their extremely cumbersome system of numbers, they evolved very elaborate “finger” arithmetic.

Arabic numbering system that came originally from India had a big advantage over Roman numerals because of its concept of *place value*. One column stands for the ones, the next column for tens, next for hundreds, and so on. Take the problem of multiplying MMMCCCCLVIII (3458) by CCCCLIX (459). Employing the Arabic system, pen and paper, we could get answer in 30 seconds or so. By Roman method, even if we try our best waggling finger as fast as possible, it takes something like ten minutes!

After classical antique come middle ages, with focus on completely different matters. No traces of any significant improvements in science. No new calculating devices either.

It was Renaissance that brought the secular<sup>1</sup> themes back to focus.

As mathematicians expanded the boundaries of geometry, algebra and number theories, the outcry for help became greater and greater.

*John Napier* (1550-1617), the Scottish inventor of logarithms, invented Napier's rods (sometimes called "Napier's bones") to simplify the task of multiplication.

The first to really achieve any success with mechanical calculating machine was *Wilhelm Schickard* (1592-1635), a graduate of the University of Tübingen (Germany). A brief description of the device (that could add, subtract, multiply, and divide) is contained in two letters to Johannes Kepler. Unfortunately, at least one copy of the machine burned up in a fire, and Schickard himself died of bubonic plague in 1635, during the Thirty Years' War. So this invention was lost.

---

<sup>1</sup> worldly, non-sacral

In 1641 the French mathematician and philosopher *Blaise Pascal* (1623-1662) built a mechanical adding machine “arithmetique”, a brass box the size of a loaf of bread, with eight dials on its face, that one operated by using stylus to input numbers. “Arithmetique” was less sophisticated than Schickard’s lost machine, and it could only add and subtract.

Similar work was done by *Gottfried Wilhelm Leibniz* (1646-1716), but his device was capable of performing all four basic arithmetic operations. Leibniz also advocated use of the binary system for doing calculations.

Up until the dawn of the 19<sup>th</sup> century, the attempts to extend the human mind were limited to manually operated devices. The abacus, Pascal’s “arithmetique”, Leibniz’s Wheel- they all required an operator who did each step in sequence.

Yet concept of *programming* was not that new. Music boxes clocks and various automata had made use of programming principle for hundreds of years.

*Joseph-Marie Jacquard* (1752-1834) invented a loom that could automate textile manufacturing and weave complicated patterns described by holes in punched cards.

*Charles Babbage* (1791-1871) worked on two mechanical devices: the *Difference Engine* and the far more ambitious *Analytical Engine* (a predecessor of the modern digital computer), but neither worked satisfactorily. He envisioned a steam-powered machine with two major parts. The first was a “mill” to perform arithmetical operations (a “central processing unit”). The second was a “store” to manage variables and retain the answers to problems solved (“memory”). Babbage intended to use Jackard’s system of punched cards to program the machine.

One of Babbage's friends, mathematician *Ada Augusta Byron, Countess of Lovelace* (1815-1852), sometimes called the "first programmer" has written on Babbage's machine. The programming language Ada was named for her.

*William Stanley Jevons* (1835-1882), a British economist and logician, built a machine in 1869 to solve logic problems. It was "the first such machine with sufficient power to solve a complicated problem faster than the problem could be solved without the machine's aid." (Gardner) It is now in the Oxford Museum of the History of Science.

*Herman Hollerith* (1860-1929) invented the modern punched card (inspired by Jacquards solution) for use in a machine he designed to help tabulate the American 1890 census.

## 1900 – 1939 The Rise of Mathematics

In 1928, the German mathematician *David Hilbert* (1862-1943) addressed the International Congress of Mathematicians. He posed among others following three fundamental questions:

- Is mathematics *complete*; i.e. can every mathematical statement be either proved or disproved?
- Is mathematics *consistent*, that is, is it true that statements such as " $0 = 1$ " cannot be proved by valid methods?
- Is mathematics *decidable*, that is, is there a mechanical method that can be applied to any mathematical assertion and (at least in principle) will eventually tell whether that assertion is true or not? This last question was called the *Entscheidungsproblem*.

In 1931, *Kurt Gödel* (1906-1978) answered two of Hilbert's questions. He showed that every sufficiently powerful formal system is either inconsistent or incomplete. Also, even if an axiom system is consistent, this consistency cannot be proved within itself. The third question remained open, with '*provable*' substituted for '*true*'.

In 1936, *Alan Turing* (1912-1954) provided a solution to Hilbert's Entscheidungsproblem by conceiving a formal model of a computer - *the Turing machine* - and showing that there were problems that a machine could not solve. One such problem is the so-called "*halting problem*": given a program, does it halt on all inputs?

## 1940's: First Electronic Digital Computer

The World War II urged the development of the general-purpose electronic digital computer for ballistics calculations. At Harvard, *Howard H. Aiken* (1900-1973) built the *Mark I* electromechanical computer in 1944, with the assistance of IBM.

Military code-breaking also led to computational projects. Alan Turing was involved in the breaking of the code behind the German machine, *the Enigma*, at Bletchley Park in England. The British built a computing device, *the Colossus*, to assist with code-breaking.

At Iowa State University in 1939, *John Vincent Atanasoff* (1904-1995) and *Clifford Berry* designed and built an electronic computer for solving systems of linear equations, but it never worked properly.

*John William Mauchly* (1907-1980) with J. Presper Eckert, Jr. (1919-1995), designed and built the *ENIAC*, a general-purpose electronic computer originally intended for artillery calculations. The ENIAC was built at the Moore School at the University of Pennsylvania, and was finished in 1946.

In 1944, *Mauchly*, *Eckert*, and *John von Neumann* (1903-1957) were designing a stored-program electronic computer, the *EDVAC*. Von Neumann's report, "*First Draft of a Report on the EDVAC*", was very influential and contains many of the ideas still used in most modern digital computers, including a merge sort. Eckert and Mauchly went on to build *UNIVAC*.

*Maurice Wilkes* (b. 1913), working in Cambridge, England, built the *EDSAC*, a computer based on the EDVAC. *F. C. Williams* (b. 1911) and others at Manchester University built the Manchester Mark I, one version of which was working as early as June 1948. This machine is sometimes called the first stored-program digital computer.

The invention of the transistor in 1947 by Bardeen, Brattain, and Shockley transformed the computer and made the microprocessor revolution possible. For this discovery they won the 1956 Nobel Prize in physics.

*Jay Forrester* (b. 1918) invented magnetic core memory 1949.

## 1950's

*Grace Murray Hopper* (1906-1992) conceived of the idea of a *compiler*, in 1951. She even invented the language APT.<sup>2</sup>

*John Backus* and others developed the first *FORTRAN* compiler in April 1957.

*LISP*, a list-processing language for artificial intelligence programming, was invented by John McCarthy about 1958. Alan Perlis, John Backus, Peter Naur and others developed *Algol*.

In hardware, *Jack Kilby* (Texas Instruments) and *Robert Noyce* (Fairchild Semiconductor) invented the *integrated circuit* in 1959.

*Edsger Dijkstra* created an efficient algorithm for shortest paths in graphs as a demonstration of the ARMAC computer in 1956. He also made an efficient algorithm for the minimum spanning tree in order to minimize the wiring needed for the X1 computer.

## 1960's

In the 1960's, *computer science* came into its own as a discipline. In fact, the term was coined by *George Forsythe*, a numerical analyst. *The first computer science department was formed at Purdue University in 1962.*

Operating systems made major advances. Fred Brooks at IBM designed System/360. Edsger Dijkstra at Eindhoven designed the THE multiprogramming system.

At the end of the decade, *ARPAnet*, a precursor to today's *Internet*, began to be constructed.

Many new programming languages were invented, such as *BASIC* (developed c. 1964 by *John Kemeny* (1926-1992) and *Thomas Kurtz* (b. 1928)).

The 1960's also saw the rise of automata theory and the theory of formal languages. Big names here include *Noam Chomsky* and *Michael Rabin*. Chomsky later became well-known for his theory that language is "hard-wired" in human brains.

---

<sup>2</sup> Earlier, in 1947, Hopper was first to coin the word "computer bug".

Proving correctness of programs using formal methods also began to be more important in this decade. The work of *Tony Hoare* played an important role. Hoare also invented *Quicksort*.

*Ted Hoff* and *Federico Faggin* at Intel designed the first microprocessor (computer on a chip) in 1969-1971.

A rigorous mathematical basis for the analysis of algorithms began with the work of *Donald Knuth*, author of *The Art of Computer Programming*.

## 1970's

The theory of databases saw major advances with the work of *Edgar F. Codd* on *relational databases*.

*Unix*, a very influential operating system, was developed at Bell Laboratories by *Ken Thompson* and *Dennis Ritchie*. Brian Kernighan and Ritchie together developed programming language *C*.

Other new programming languages, such as *Pascal* (invented by *Niklaus Wirth*) and *Ada* (developed by a team led by *Jean Ichbiah*), appeared.

The first *RISC* architecture was begun by *John Cocke* in 1975, at the Thomas J. Watson Laboratories of IBM. Similar projects started at Berkeley and Stanford around this time.

The 1970's also bring the rise of the *supercomputer*. *Seymour Cray* designed the CRAY-1, which was first shipped in March 1976. It could perform 160 million operations in a second. Cray Research was taken over by Silicon Graphics.

There were also major advances in algorithms and computational complexity. In 1971, Steve Cook published his seminal paper on NP-completeness, and shortly thereafter, Richard Karp showed that many natural combinatorial problems were NP-complete. Whit Diffie and Martin Hellman published a paper that introduced the theory of public-key cryptography.

In 1979, three graduate students in North Carolina developed a *distributed news server* which eventually became *Usenet*.

## 1980's

This decade also saw the rise of the *personal computer*, thanks to *Steve Wozniak* and *Steve Jobs*, founders of Apple Computer.

In 1981, the first truly successful *portable computer* was marketed, the Osborne I. In 1984, Apple first marketed the Macintosh computer.



## 1990's and Beyond

*Parallel computers* continue to be developed.

*Biological computing*, with the recent work of Len Adleman on doing computations via DNA, has great promise.

*Quantum computing* gets a boost with the discovery by Peter Shor that integer factorization can be performed efficiently on a (theoretical) quantum computer.

The "*Information Superhighway*" links more and more computers worldwide.

Computers get smaller and smaller; the birth of *nano-technology*.

To conclude this introductory historical overview we can note that the development of computing devices follows the needs of human civilization. In the beginning, computers were needed to solve practical problem of performing long and tedious calculations in a fast and reliable way.

The era of focusing on algorithmic aspects of computing is coupled to the dominance of mathematicians, logicians and even physicists, as they were not only the first users of computers, but also, they were creating new concepts, designing and building new machines.

More recent developments however opened entirely new areas of application for computers. Nowadays computers can be found virtually everywhere, and the majority of users are no longer scientists or technicians but "common people". That has as a consequence a new ever growing demand for improved graphic features (especially stimulated by the enormous market for computer games) even improved audio capabilities and user-friendly interface. The enormous expansion of Internet is one of the motors of progress for personal computers.

Modern development doesn't only include home-markets but also targets the professional segment that demands advanced data bases, expert systems, distributed parallel systems, and many more fields.

# 1 LEIBNIZ: LOGICAL CALCULUS

Gottfried Wilhelm von Leibniz



Born: 1 July 1646 in Leipzig, Saxony (now Germany)  
Died: 14 Nov 1716 in Hannover, Hanover (now Germany)

G. W. Leibniz was born in Leipzig in 1646. His father, a professor of philosophy at the university of Leipzig, has died when child was six years old, and the boy was brought up by his mother.

In his early teens Leibniz started studying Aristotle's logic. What fascinated him the most was the Aristotelian division of concepts in *categories*. He was inspired to develop his own logical system based on alphabet whose elements would represent *concepts*.

Starting from Aristotle Leibniz conceived of a universal artificial language to formulate propositions in which all human knowledge could be expressed, with "calculational" rules that would expose logical interrelationships among those propositions. He has remained under Aristotle's spell the rest of his life. For his bachelor's degree he wrote on Aristotelian metaphysics.

His other field of interest was legal studies, so he obtained his second bachelor's degree in law, dealing in his thesis with the use of systematic logic in legal matters.

Leibniz made his first contribution to mathematic in his doctoral dissertation in philosophy. As a step towards the alphabet of concepts, he systematically studied complex arrangements made of basic elements, that he even continued to develop in a monograph "Dissertatio de Arte Combinatoria".

Leibniz had a great vision of really amazing scope.

He has developed the notations for the differential and integral calculus that are still in use today, that made it easy to perform complicated calculations with help of simple and clear-cut rules. In his vision similar could be done for all human knowledge.

He also dreamed of machines capable of carrying out calculations, freeing the mind for creative thought: “*For it is unworthy of excellent men to lose hours like slaves in the labor of calculation which could safely be relegated to anyone else if the machine were used.*”

Leibniz developed a machine that could not only add and subtract but also multiply, divide, and extract square roots. The Leibniz calculator was gear-operated, and it provided a carry from one order to the next.

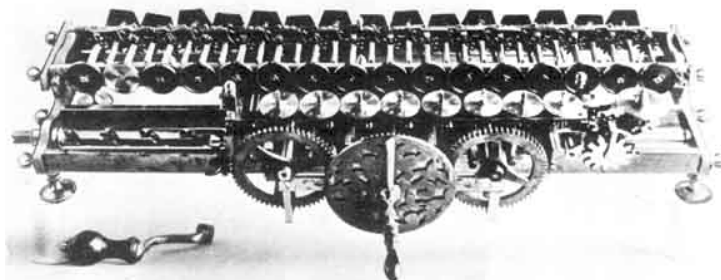

Figure 1 Leibniz’s calculating machine

It is example of algebra that Leibniz cites constantly to show how a system of properly chosen symbols is useful and indeed crucial for deductive thought.

“Part of the secret of algebra consists of the characteristic, that is to say of the art of properly using the symbolic expressions. This care for proper use of symbols was to be the “thread of Ariadne” that would guide the scholar...”

The seventeenth-century mathematics has two major developments that stimulated the development of mathematical research:

- Systematization of techniques dealing with algebraic expressions
- Reduction of geometry to algebra by representing points by pairs of numbers (Descartes, Fermat)

Much of work has been done investigating *limit processes*, that is, searching approximate solutions that approach the exact solution in the limit.

Following elegant expression is the Leibniz’s own result:

$$\frac{\pi}{4} = 1 - \frac{1}{3} + \frac{1}{5} - \frac{1}{7} + \frac{1}{9} - \frac{1}{11} + \dots$$

That can be interpreted as the area of a circle with radius  $\frac{1}{2}$ , expressed as infinite series of odd numbers alternately added and subtracted.

Generally, finding areas of figures with curved boundaries was one kind of problems solved by limit processes. Another kind of problem was finding the rates of change, such as the varying speed. Leibniz recognized that mathematical operations required for calculation of those two types were *inverse* of each other (fundamental theorem of the calculus). Nowadays these operations are called *integration* (in Leibniz notation  $\int$  is actually modified “S”) and *differentiation* (in Leibniz notation “d” suggests “difference”).

## Calculus Ratiocinator

“I am convinced more and more of the utility and reality of this general science, and I see that very few people have understood its extent... This characteristic consists of a certain script or language... that perfectly represents the relationships between our thoughts. The characters would be quite different from what has been imagined up to now. Because one has forgotten the principle that the characters of this script should serve invention and judgement as in algebra or arithmetic. This script will have great advantages, among others; there is one that seems particularly important to me. This is that it will be impossible to write, using these characters, chimerical notions (chimères) such as suggest themselves to us. An ignoramus will not be able to use it, or, in striving in doing so, he himself will become erudite.”<sup>3</sup>

Leibniz saw his grand program as consisting of three major steps:

1. Before the appropriate symbols could be selected, it would be necessary to create an information bank encompassing the full extent of human knowledge.
2. Select the key underlying notions and provide appropriate symbols for each of them.
3. Finally, the rules of deduction could be reduced to manipulations of these symbols. That is what Leibniz called a *calculus ratiocinator* and what nowadays might be called *symbolic logic*.

For Leibniz nothing, absolutely nothing about the world was in any way undetermined or accidental; everything followed a plan, clear in the mind of God, by means of which he created the best world that can be created. Hence all aspects of the world were connected by links one could hope to discover by rational means.

Leibniz really did attempts to produce *calculus ratiocinator*, as illustrated in following.

**DEFINITION 3.** A is in L, or L contains A, is the same as to say that L can be made to coincide with a plurality of terms taken together of which A is one.  $B \oplus N = L$  signifies that B is in L and that B and N together compose or constitute L. The same thing holds for larger number of terms.

**AXIOM 1.**  $B \oplus N = N \oplus B$ .

**POSTULATE.** Any plurality of terms, as A and B, can be added to compose  $A \oplus B$ .

**AXIOM 2.**  $A \oplus A = A$ .

**PROPOSITION 5.** If A is in B and  $A = C$ , then C is in B.

**PROPOSITION 6.** If C is in B and  $A = B$ , then C is in A.

**PROPOSITION 7.** A is A.

(For A is in  $A \oplus A$  (by Definition 3). Therefore (by Proposition 6) A is in A.)

....

**PROPOSITION 20.** If A is in M and B is in N, then  $A \oplus B$  is in  $M \oplus N$ .

Figure 2 Sample from one of Leibniz’s logical calculi

<sup>3</sup> The letter from Leibniz to Jean Galloys, dated December 1678.

More than a century and a half ahead of his time, Leibniz proposed an algebra of logic, an algebra that would specify the rules for manipulating logical concepts in the manner that ordinary algebra specifies the rules for manipulating numbers.

The idea was something like combining two collections of things into a single collection containing all of the items in either one. The most striking rule is Leibniz's Axiom 2 that says that combining plurality of terms with itself yield nothing new.

### **Language and Mind**

Some scholars have suggested that Leibniz should be regarded as one of the first thinkers to envision something like the idea of artificial intelligence.

Whether or not he should be regarded as such, it is clear that Leibniz, like today's cognitive scientists, *saw an intimate connection between the form and content of language, and the operations of the mind*. Indeed, according to his own testimony in the *New Essays*, he "really believe[s] that languages are the best mirror of the human mind, and that a precise analysis of the signification of words would tell us more than anything else about the operations of the understanding".

This view of Leibniz's led him to formulate a plan for a "universal language," an artificial language composed of symbols, which would stand for concepts or ideas, and logical rules for their valid manipulation. He believed that such a language would perfectly mirror the processes of logical human reasoning. It is this plan that has led some to believe that Leibniz came close to anticipating artificial intelligence.

At any rate, Leibniz's writings about this project (which, it should be noted, he never got the chance to actualize) reveal significant insights into his understanding of the nature of human reasoning. This understanding, it turns out, is not that different from contemporary conceptions of the mind, and many of his discussions bear considerable relevance to discussions in the cognitive sciences.

According to Leibniz, natural language, despite its powerful resources for communication, often makes reasoning obscure since it is an imperfect mirror of comprehensible thoughts. As a result, it is often difficult to reason with the apparatus of natural language, "since it is full of innumerable equivocations". Perhaps this is because of his view that the terms of natural language stand for complex, or derivative, concepts - concepts which are composed of, and reducible to, simpler concepts.

With this "combinatorial" view of concepts in hand, Leibniz notices "that all human ideas can be resolved into a few as their primitives". We could then assign symbols, or "characters," to these primitive concepts from which we could form characters for derivative concepts by means of combinations of the symbols. As a result, Leibniz tells us, "it would be possible to find correct definitions and values and, hence, also the properties which are demonstrably implied in the definitions".

The totality of these symbols would form a "universal characteristic," an ideal language in which all human concepts would be perfectly represented, and their constitutive nature perfectly transparent. He writes in *The Art of Discovery* that "there are certain primitive terms which can be posited, if not absolutely, at least relatively to us" The suggestion seems to be that even if we cannot provide a catalogue of absolutely primitive concepts, we can nevertheless construct a characteristic based on concepts which cannot be further resolved by humans.

In addition to the resolution of concepts, and their symbolic assignments, Leibniz envisages the formulation of logical rules for the universal characteristic. He claims that "it is plain that men make use in reasoning of several axioms which are not yet quite certain" (*The Method of Certitude and the Art of Discovery*). Yet with the explicit formulation of these rules for the logical manipulation of the symbols - rules which humans use in reasoning - we would be in possession of a universal language which would mirror the relations between the concepts used in human reasoning.

Indeed, the universal characteristic was intended by Leibniz as an instrument for the calculation of truths. Like formal logic systems, it would be a language capable of representing valid reasoning patterns by means of the use of symbols. Unlike formal logic systems, however, the universal language would also express the content of human reasoning in addition to its formal structure. In Leibniz's mind, "this language will be the greatest instrument of reason," for "when there are disputes among persons, we can simply say: Let us calculate, without further ado, and see who is right" (*The Art of Discovery*).

Judging from Leibniz's plans for a universal language, it is clear that Leibniz had a specific view about the nature of human cognitive processes, particularly about the nature of human reasoning. According to this view, cognition is essentially symbolic: it takes place in a system of representations which possesses language-like structure.

Indeed, it was Leibniz's view that "all human reasoning uses certain signs or characters," (*On the Universal Science: Characteristic*) and "if there were no characters, we could neither think of anything distinctly nor reason about it" (*Dialogue*).

Add to this conception Leibniz's view that human cognitive processes follow determinable axioms of logic, and the picture that emerges is one according to which *the mind operates, at least when it comes to logical reasoning, by following implicit algorithmic procedures.*

Regardless of whether or not Leibniz should be seen as the pioneer of artificial intelligence, he did conceive of human cognition in essentially computational terms. In fact, as early as 1666, remarking favorably on Hobbes' writings, Leibniz wrote: "Thomas Hobbes, everywhere a profound examiner of principles, rightly stated that everything done by our mind is a *computation* " (*On the Art of Combinations*).

## 2 BOOLE: LOGIC AS ALGEBRA

George Boole

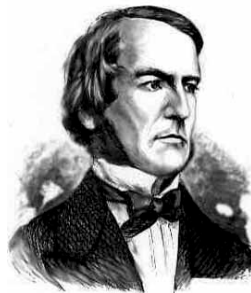

Born: 2 Nov 1815 in Lincoln, Lincolnshire, England  
Died: 8 Dec 1864 in Ballintemple, County Cork, Ireland

George Boole first attended a school in Lincoln, then a commercial school. His early instruction in mathematics, however, was from his father (a professional shoemaker) who also gave George a liking for constructing optical instruments. George's interests turned to languages and he received instruction in Latin from a local bookseller.

Boole did not study for an academic degree, but from the age of 16 he was an assistant school teacher. He maintained his interest in languages and intended to enter the Church. From 1835, however, he seems to have changed his mind for he opened his own school and began to study mathematics on his own.

At this time Boole studied the works of Laplace and Lagrange, making notes which would later be the basis for his first mathematics paper. However he did receive encouragement from Duncan Gregory who at this time was in Cambridge and the editor of the recently founded *Cambridge Mathematical Journal*.

Boole was unable to study courses at Cambridge as he required the income from his school to look after his parents. However he began publishing in the *Cambridge Mathematical Journal*. Under the influence of Duncan Gregory he began to study algebra.

An application of algebraic methods to the solution of differential equations was published by Boole in the *Transactions of the Royal Society* and for this work he received the Society's Royal Medal. His mathematical work was beginning to bring him fame.

Boole was appointed to the chair of mathematics at Queens College, Cork in 1849. He taught there for the rest of his life, gaining a reputation as an outstanding teacher.

In 1854 he published *An investigation into the Laws of Thought*, on which are founded the Mathematical Theories of Logic and *Probabilities*. Boole approached logic in a new way reducing it to a simple algebra, incorporating logic into mathematics. He pointed out the analogy between algebraic symbols and those that represent logical forms. It began the algebra of logic called Boolean algebra which now finds application in computer construction, switching circuits etc.

### Boole's Algebra of Logic

The classical logic of Aristotle that had so fascinated the young Leibniz involved sentences as

- All cows are mammals.
- No fish is intelligent.
- Some people speak Greek.

Boole came to realize that what is significant in logical reasoning about such words as “cows” “people” or “fish” is a *class* or *collection* of things. He also came to see how this kind of reasoning can be expressed in terms of an algebra of such classes. If the letter  $x$  and  $y$  stand for two particular classes, then Boole wrote  $xy$  for the class that is both  $x$  and  $y$ . Boole says

‘...If an adjective, as “good” is employed as term of description, let us represent by a letter, as  $y$ , all things to which the description “good” is applicable, i.e. “all good things”, or the class “good things”. Let it further be agreed, that by the combination  $xy$  shall be represented that class of things to which the names or descriptions represented by  $x$  and  $y$  are simultaneously applicable. Thus if  $x$  alone stands for “white things”, and  $y$  for “sheep”, let  $xy$  stand for “white sheep”; and in like manner, if  $z$  stands for “horned things”, let  $zxy$  represent “horned white sheep”.’

Boole thought of this operation applied to classes as being in some ways like the operation of multiplication applied to numbers. However, there is a crucial difference: If  $y$  is the class of sheep, what is  $yy$ ? The class of things that are sheep and also...sheep. So  $yy = y$ .<sup>4</sup>

This led Boole to ask the question: In ordinary algebra, where  $x$  stands for a number, when is the equation  $xx = x$  true? The answer is that  $x$  is 0 or 1.

This led Boole to conclude that the algebra of logic was precisely what ordinary algebra would become if it were restricted to the values of 0 and 1.

$$0x = 0, 1x = x.$$

In terms of classes 0 is interpreted as the empty set, and 1 as the universe of discourse (which contains every object under consideration).

If  $x$  and  $y$  represent two classes, Boole took  $x+y$  to represent the class of all things to be found either in  $x$  or in  $y$ , i.e. the *union* of  $x$  and  $y$ .

Boole wrote  $x-y$  for a class of things in  $x$  but not in  $y$ .

The class  $x \cdot y$  includes all things to be found both in  $x$  and in  $y$ , i.e. the intersection of  $x$  and  $y$ .

---

<sup>4</sup> Boole's equation  $xx = x$  can be compared to Leibniz's  $A \oplus A = A$ . In both cases an operation, intended to be applied to pairs of items, when applied to an item and itself, yields the very same item as result.



Example.

$xx=x$  can be written as  $x - xx = 0$  or  $x(1-x) = 0$ .

Nothing can both belong and not belong to a given class  $x$ , which is Aristotle's principle of contradiction.

In formal terms, a Boolean algebra is a structure containing a set  $B$ , two binary functions,  $\wedge$  (intersection) and  $\vee$  (union) on  $B$ , one unary function  $\neg$  (complementation) on  $B$ , and two distinguished elements  $0$  (the null-element) and  $1$  (the unit-element) of  $B$ , satisfying the following axioms, for all  $x, y, z \in B$ :

$$\begin{aligned}x \vee (y \vee z) &= (x \vee y) \vee z \text{ and } x \wedge (y \wedge z) = (x \wedge y) \wedge z. \\x \vee y &= y \vee x \text{ and } x \wedge y = y \wedge x. \\x \vee (y \wedge z) &= (x \vee y) \wedge (x \vee z) \text{ and } x \wedge (y \vee z) = (x \wedge y) \vee (x \wedge z). \\x \vee \neg x &= 1 \text{ and } x \wedge \neg x = 0. \\x \vee 0 &= x \text{ and } x \wedge 1 = x.\end{aligned}$$

A binary relation  $\leq$  on  $B$  is defined as  $x \leq y \leftrightarrow x \wedge y = x$ ;  $\leq$  partially orders  $B$ . To see that the algebra of sets is a Boolean algebra let  $B$  be the power set of any set  $S$ ,  $\wedge$  be set-theoretic intersection,  $\vee$  be set-theoretic union,  $\neg$  be complementation with respect to  $S$ ,  $0$  be the null set, and  $1$  be  $S$ . Then  $\leq$  is set-theoretic inclusion.

The binary  $0$  and  $1$  states are naturally related to the true and false logic variables. We will find the following Boolean algebra useful. Consider two logic variables  $A$  and  $B$  and the result of some Boolean logic operation  $Q$ . We can define

A useful way of displaying the results of a Boolean operation is with a truth table.

We list a few Boolean rules in following figure:

$A \cdot 0 = 0$
$A + 0 = A$
$A \cdot 1 = A$
$A + 1 = 1$
$A \cdot A = A$
$A + A = A$
$A \cdot \bar{A} = 0$
$A + \bar{A} = 1$

Figure 3 Properties of Boolean Operations.





The Boolean operations obey the usual commutative, distributive and associative rules of normal algebra:

$\bar{\bar{A}}$	=	$A$
$A \cdot B$	=	$B \cdot A$
$A + B$	=	$B + A$
$A \cdot (B + C)$	=	$A \cdot B + A \cdot C$
$A \cdot (B \cdot C)$	=	$(A \cdot B) \cdot C$
$A + (B + C)$	=	$(A + B) + C$
$A + A \cdot B$	=	$A$
$A \cdot (A + B)$	=	$A$
$A \cdot (\bar{A} + B)$	=	$A \cdot B$
$A + \bar{A} \cdot B$	=	$A + B$
$\bar{A} + A \cdot B$	=	$\bar{A} + B$
$\bar{A} + A \cdot \bar{B}$	=	$\bar{A} + \bar{B}$

**Figure 4** Boolean commutative, distributive and associative rules.

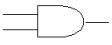
Boolean algebra has wide applications in telephone switching and the design of modern computers. Boole's work has to be seen as a fundamental step in today's computer revolution.

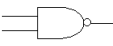
Summary of Logic Gates

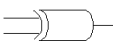
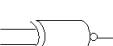
AND		<table border="1"> <thead> <tr> <th>A</th> <th>B</th> <th><math>A \cdot B</math></th> </tr> </thead> <tbody> <tr><td>0</td><td>0</td><td>0</td></tr> <tr><td>0</td><td>1</td><td>0</td></tr> <tr><td>1</td><td>0</td><td>0</td></tr> <tr><td>1</td><td>1</td><td>1</td></tr> </tbody> </table>	A	B	$A \cdot B$	0	0	0	0	1	0	1	0	0	1	1	1
A	B	$A \cdot B$															
0	0	0															
0	1	0															
1	0	0															
1	1	1															
OR		<table border="1"> <thead> <tr> <th>A</th> <th>B</th> <th><math>A + B</math></th> </tr> </thead> <tbody> <tr><td>0</td><td>0</td><td>0</td></tr> <tr><td>0</td><td>1</td><td>1</td></tr> <tr><td>1</td><td>0</td><td>1</td></tr> <tr><td>1</td><td>1</td><td>1</td></tr> </tbody> </table>	A	B	$A + B$	0	0	0	0	1	1	1	0	1	1	1	1
A	B	$A + B$															
0	0	0															
0	1	1															
1	0	1															
1	1	1															
NOT		<table border="1"> <thead> <tr> <th>A</th> <th><math>\bar{A}</math></th> </tr> </thead> <tbody> <tr><td>0</td><td>1</td></tr> <tr><td>1</td><td>0</td></tr> </tbody> </table>	A	$\bar{A}$	0	1	1	0									
A	$\bar{A}$																
0	1																
1	0																
NAND		<table border="1"> <thead> <tr> <th>A</th> <th>B</th> <th><math>\overline{A \cdot B}</math></th> </tr> </thead> <tbody> <tr><td>0</td><td>0</td><td>1</td></tr> <tr><td>0</td><td>1</td><td>1</td></tr> <tr><td>1</td><td>0</td><td>1</td></tr> <tr><td>1</td><td>1</td><td>0</td></tr> </tbody> </table>	A	B	$\overline{A \cdot B}$	0	0	1	0	1	1	1	0	1	1	1	0
A	B	$\overline{A \cdot B}$															
0	0	1															
0	1	1															
1	0	1															
1	1	0															
NOR		<table border="1"> <thead> <tr> <th>A</th> <th>B</th> <th><math>\overline{A + B}</math></th> </tr> </thead> <tbody> <tr><td>0</td><td>0</td><td>1</td></tr> <tr><td>0</td><td>1</td><td>0</td></tr> <tr><td>1</td><td>0</td><td>0</td></tr> <tr><td>1</td><td>1</td><td>0</td></tr> </tbody> </table>	A	B	$\overline{A + B}$	0	0	1	0	1	0	1	0	0	1	1	0
A	B	$\overline{A + B}$															
0	0	1															
0	1	0															
1	0	0															
1	1	0															
XOR		<table border="1"> <thead> <tr> <th>A</th> <th>B</th> <th><math>A \oplus B</math></th> </tr> </thead> <tbody> <tr><td>0</td><td>0</td><td>0</td></tr> <tr><td>0</td><td>1</td><td>1</td></tr> <tr><td>1</td><td>0</td><td>1</td></tr> <tr><td>1</td><td>1</td><td>0</td></tr> </tbody> </table>	A	B	$A \oplus B$	0	0	0	0	1	1	1	0	1	1	1	0
A	B	$A \oplus B$															
0	0	0															
0	1	1															
1	0	1															
1	1	0															
XNOR		<table border="1"> <thead> <tr> <th>A</th> <th>B</th> <th><math>\overline{A \oplus B}</math></th> </tr> </thead> <tbody> <tr><td>0</td><td>0</td><td>1</td></tr> <tr><td>0</td><td>1</td><td>0</td></tr> <tr><td>1</td><td>0</td><td>0</td></tr> <tr><td>1</td><td>1</td><td>1</td></tr> </tbody> </table>	A	B	$\overline{A \oplus B}$	0	0	1	0	1	0	1	0	0	1	1	1
A	B	$\overline{A \oplus B}$															
0	0	1															
0	1	0															
1	0	0															
1	1	1															

**Figure 5** Logic gates

One day in 1864 he walked from his residence to the College, a distance of two miles, in the drenching rain, and lectured in wet clothes. The result was a feverish cold which soon fell upon his lungs and terminated his career ....

De Morgan said: "Boole's system of logic is but one of many proofs of genius and patience combined. ... That the symbolic processes of algebra, invented as tools of numerical calculation, should be competent to express every act of thought, and to furnish the grammar and dictionary of an all-containing system of logic, would not have been believed until it was proved. "

### 3 FREGE: MATEMATICS AS LOGIC

Friedrich Ludwig Gottlob Frege

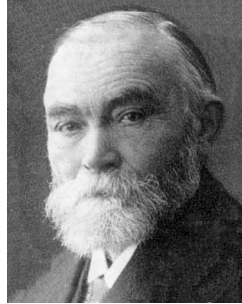

Born: 8 Nov 1848 in Wismar, Mecklenburg-Schwerin (now Germany)  
Died: 26 July 1925 in Bad Kleinen, Germany

Gottlob Frege was the first to fully develop the main thesis of logicism, *that mathematics is reducible to logic.*

Frege received his education at the universities of Jena (1869-71) and Göttingen (1871-1873) where he studied mathematics, physics and chemistry. He then taught at Jena in the department of mathematics where he remained, first as a lecturer and then a professor, for the rest of his working life.

Frege lectured on all branches of mathematics although his mathematical publications outside the field of logic are few. His writings on the philosophy of logic, philosophy of mathematics, and philosophy of language are of major importance. He once said: *Every good mathematician is at least half a philosopher, and every good philosopher is at least half a mathematician.* “

His work was not particularly well received; mainly it was ignored. While volume 2 of *The Basic Laws of Arithmetic* was at the printers he received a letter from Bertrand Russell. Russell pointed out, with great modesty, that the Russell paradox<sup>5</sup> gave a contradiction in Frege's system of axioms. After many letters between the two Frege modified one of his axioms and explains in an appendix to the book that this was done to restore the consistency of the system. However with this modified axiom, many of the theorems of Volume 1 do not go through and Frege must have known this. He probably never realised that even with the modified axiom the system is inconsistent since this was not shown until after Frege's death.

Frege was a major influence on Peano and Bertrand Russell.

---

<sup>5</sup> See Appendix on Russell paradox

## Frege's Advances in Logic

Frege virtually founded the modern discipline of mathematical logic. He forever changed the way philosophers and mathematical logicians think about the predicate calculus, the analysis of simple sentences and quantifier phrases, proofs, the foundations of mathematics, definitions, and the 'natural numbers'.

### The Predicate Calculus

In an attempt to realize Leibniz's ideas for a language of thought and a rational calculus, Frege developed a formal notation for regimenting thought and reasoning (*Begriffsschrift*). He has developed the first predicate calculus, although we no longer use his notation.

A predicate calculus is a formal system with two components: a formal language and a logic. The formal language Frege designed was capable of:

- (a) expressing predicational statements of the form ' $x$  falls under the concept  $F$ ' and ' $x$  bears relation  $R$  to  $y$ ', etc.,
- (b) expressing complex statements such as 'it is not the case that ...' and 'if ... then ...', and
- (c) expressing 'quantified' statements of the form 'Some  $x$  is such that ... $x$ ...' and 'Every  $x$  is such that ... $x$ ...'.

The logic of Frege's calculus was a set of rules that govern when some statements of the language may be correctly inferred from others.

Frege's system was powerful enough to resolve the essential logic of mathematical reasoning.

### The Analysis of Atomic Sentences and Quantifier Phrases

The most important insight underlying Frege's calculus was his 'function-argument' analysis of sentences. This freed him from the limitations of the 'subject-predicate' analysis of sentences that formed the basis of Aristotelian logic and it made it possible for him to develop a general treatment of quantification.

In traditional Aristotelian logic, the subject of a sentence and the direct object of a verb are not on a logical par. The rules governing the inferences between statements with different but related subject terms are different from the rules governing the inferences between statements with different but related verb complements.

For example, in Aristotelian logic, the rule which permits the valid inference from 'Fred loves Annie' to 'Something loves Annie' is different from the rule which permits the valid inference from 'Fred loves Annie' to 'Fred loves something'. The rule governing the first inference is a rule which applies only to the subject terms 'Fred' and 'Something'. The rule governing the second inference applies only to the transitive verb complements 'Annie' and 'something'. In Aristotelian logic, these inferences have nothing in common.

In Frege's logic, a single rule governs both the inference from 'Fred loves Annie' to 'Something loves Annie' and the inference from 'Fred loves Annie' to 'Fred loves something'. This was made possible by Frege's analysis of atomic and quantified sentences.

Frege took intransitive verb phrases such as 'is happy' to be functions of one variable (' $x$  is happy'), and resolved the sentence "Fred is happy" in terms of the application of the function denoted by 'is happy' to the argument denoted by 'Fred'. In addition, Frege took the verb phrase 'loves' to be a function of two variables (' $x$  loves  $y$ ') and resolved the sentence 'Fred loves Annie' as the application of the function denoted by ' $x$  loves  $y$ ' to the objects denoted by 'Fred' and 'Annie' respectively.

In effect, Frege saw no distinction between the subject 'Fred' and the direct object 'Annie'. What is logically important is that 'loves' denotes a function of 2 arguments, that 'gives' denotes a function of 3 arguments ( $x$  gives  $y$  to  $z$ ), etc.

This analysis allowed Frege to develop a more systematic treatment of quantification than that offered by Aristotelian logic. No matter whether the quantified expression 'something' appears within a subject ("Something loves Annie") or within a predicate ("Fred loves something"), it is to be resolved in the same way. In effect, Frege treated quantified expressions as variable-binding operators. The variable-binding operator 'some  $x$  is such that' can bind the variable ' $x$ ' in the expression ' $x$  loves Annie' as well as the variable ' $x$ ' in the expression 'Fred loves  $x$ '. Thus, Frege analyzed the above inferences in the following general way:

- Fred loves Annie. Therefore, some  $x$  is such that  $x$  loves Annie.
- Fred loves Annie. Therefore, some  $x$  is such that Fred loves  $x$ .

Both inferences are instances of a single valid inference rule.

### **Proof**

As part of his predicate calculus, Frege developed a strict definition of a 'proof'. In essence, he defined a proof to be any finite sequence of well-formed statements such that each statement in the sequence either is an axiom or follows from previous members by a valid rule of inference. A proof of the statement  $B$  from the premises  $A_1, \dots, A_n$  is any finite sequence of statements (with  $B$  the final statement in the sequence) such that each member of the sequence: (a) is one of the premises  $A_1, \dots, A_n$ , or (b) is an axiom, or (c) follows from previous members of the sequence by a rule of inference. This is essentially the definition of a proof that logicians still use today.

## 4 CANTOR: INFINITY

Georg Ferdinand Ludwig Philipp Cantor



Born: 3 March 1845 in St Petersburg, Russia  
Died: 6 Jan 1918 in Halle, Germany

Georg Cantor's father was a Danish Jewish merchant that had converted to Protestantism while his mother was a Danish Roman Catholic. The family stayed in Russia for eleven years until the father's poor health forced them to move to Germany, the country Georg would call home for the rest of his life. Georg inherited considerable artistic talents from his parents.

All the Cantor children displayed an early musical and artistic talent with Georg being an outstanding violinist as well as excelling in mathematics. His father, the eternal pragmatic, saw this gift and tried to push his son into the more profitable field of engineering. Georg was not at all happy about this idea. However, after several years of training, he became so fed up with the idea that he gathered the courage to beg his father to become a mathematician. Finally, just before entering college, his father let Georg study mathematics.

In 1862, Georg Cantor entered the University of Zurich only to transfer the next year to the University of Berlin after his father's death. At Berlin he studied mathematics, philosophy and physics. There he was taught by some of the greatest mathematicians of the day including Kronecker and Weierstrass.

After receiving his doctorate in 1867, it was difficult to find good employment and Cantor was forced to accept a position as an unpaid lecturer and later as an assistant professor at the backwater University of Halle. In 1874, he married and eventually had six children.

It was in that same year of 1874 that Cantor published his first paper on the theory of sets. While studying a problem in analysis, he had dug deeply into its "foundations," especially sets and infinite sets. What he found shocked him so much that he wrote to a friend: "I see it but I don't believe it."

In a series of papers, he was able to prove among other things that the set of integers had an equal number of members as the set of even numbers, squares, cubes, and roots to equations; that the number of points in a line segment is equal to the number of points in an infinite line, a plane and all mathematical space; and that the number of transcendental numbers, values such as  $\pi$  and  $e$  that can never be the solution to any algebraic equation, were much larger than the number of integers.

Interestingly, the Jesuits also used his theory to "prove" the existence of God and the Holy Trinity. However, Cantor, who was also an excellent theologian, quickly distanced himself away from such "proofs."

Before in mathematics, infinity had been a taboo subject. Previously, Gauss had stated that infinity should only be used as "a way of speaking" and not as a mathematical value. Most mathematicians followed his advice and stayed away. However, Cantor would not leave it alone. He considered infinite sets not as merely going on forever but as completed entities, that is having an actual though infinite number of members. He called these actual infinite numbers transfinite numbers. By considering the infinite sets with a transfinite number of members, Cantor was able to come up his amazing discoveries. For his work, he was promoted to full professorship in 1879.

However, his new ideas also gained him numerous enemies. Many mathematicians just would not accept his groundbreaking ideas that shattered their safe world of mathematics. One great mathematician, Henri Poincare expressed his disapproval, stating that Cantor's set theory would be considered by future generations as "a disease from which one has recovered." However, he was kinder than another critic, Leopold Kronecker.

Kronecker was a firm believer that the only numbers were integers and that negatives, fractions, imaginary and especially irrational numbers had no business in mathematics. He simply could not handle "actual infinity." Using his prestige as a professor at the University of Berlin, he did all he could to suppress Cantor's ideas. Among other things, he delayed or suppressed completely Cantor's and his followers' publications, raged both written and verbal personal attacks against him, belittled his ideas in front of his students and blocked Cantor's life ambition of gaining a position at the prestigious University of Berlin.

Not all mathematicians were antagonistic to Cantor's ideas. Some greats such as Mittag-Leffler, Karl Weierstrass, and long-time friend Richard Dedekind supported his ideas and attacked Kronecker's actions. However, it was not enough. Like with his father before, Cantor simply could not handle it. Stuck in a third-rate institution, stripped of well-deserved recognition for his work and under constant attack by Kronecker, he suffered the first of many nervous breakdowns in 1884.

The rest of his life was spent in and out of mental institutions and his work nearly ceased completely. Much too late for him to really enjoy it, his theory finally began to gain recognition by the turn of the century. He died in a mental institution in Halle.

Whenever Cantor suffered from periods of depression he tended to turn away from mathematics and turn towards philosophy and his big literary interest which was a belief that Francis Bacon wrote Shakespeare's plays. For example in his illness of 1848 he had requested that he be allowed to lecture on philosophy instead of mathematics and he had begun his intense study of Elizabethan literature in attempting to prove his Bacon-Shakespeare theory.

Today, Cantor's work is widely accepted by the mathematical community. His theory on infinite sets reset the foundation of nearly every mathematical field and brought mathematics to its modern form. In addition, his work has helped to explain Zeno's paradoxes that plagued mathematics for 2500 years. However, his theory also has led to many new questions, especially about set theory, that should keep mathematicians busy for centuries.

Hilbert described Cantor's work as:- '...the finest product of mathematical genius and one of the supreme achievements of purely intellectual human activity.'

## 5 HILBERT: PROGRAM FOR MATHEMATICS

David Hilbert



Born: 23 Jan 1862 in Königsberg, Prussia (now Kaliningrad, Russia)  
Died: 14 Feb 1943 in Göttingen, Germany

David Hilbert attended the gymnasium in his home-town of Königsberg. After graduating from the gymnasium, he entered the University of Königsberg. There he went on to study under Lindemann for his doctorate which he received in 1885 for a thesis entitled *Über invariante Eigenschaften spezieller binärer Formen, insbesondere der Kugelfunctionen*. One of Hilbert's friends there was Minkowski, who was also a doctoral student at Königsberg, and they were to strongly influence each other.

In 1884 Hurwitz was appointed to the University of Königsberg and quickly became friends with Hilbert, a friendship which was another important factor in Hilbert's mathematical development. Hilbert was a member of staff at Königsberg from 1886 to 1895, being a Privatdozent until 1892, then as Extraordinary Professor for one year before being appointed a full professor in 1893.

In 1895, Hilbert was appointed to the chair of mathematics at the University of Göttingen, where he continued to teach for the rest of his career.

In 1902, the University of Berlin offered Hilbert Fuchs' chair. Hilbert turned down the Berlin chair, but only after he had used the offer to bargain with Göttingen and persuade them to set up a new chair to bring his friend Minkowski to Göttingen.

Hilbert's first work was on invariant theory and, in 1888, he proved his famous Basis Theorem. Twenty years earlier Gordan had proved the finite basis theorem for binary forms using a highly computational approach. Attempts to generalise Gordan's work to systems with more than two variables failed since the computational difficulties were too great. Hilbert himself tried at first to follow Gordan's approach but soon realised that a new line of attack was necessary. He discovered a completely new approach which proved the finite basis theorem for any number of variables but in an entirely abstract way. Although he proved that a finite basis existed his methods did not construct such a basis.

Hilbert submitted a paper proving the finite basis theorem to *Mathematische Annalen*. However Gordan was the expert on invariant theory for *Mathematische Annalen* and he found



Hilbert's revolutionary approach difficult to appreciate. He refereed the paper and sent his comments to Klein: "The problem lies not with the form ... but rather much deeper. Hilbert has scorned to present his thoughts following formal rules, he thinks it suffices that no one contradict his proof ... he is content to think that the importance and correctness of his propositions suffice. ... for a comprehensive work for the *Annalen* this is insufficient."

However, Hilbert had learnt through his friend Hurwitz about Gordan's letter to Klein and Hilbert wrote himself to Klein in forceful terms: "... I am not prepared to alter or delete anything, and regarding this paper, I say with all modesty, that this is my last word so long as no definite and irrefutable objection against my reasoning is raised."

At the time Klein received these two letters from Hilbert and Gordan, Hilbert was an assistant lecturer while Gordan was the recognised leading world expert on invariant theory and also a close friend of Klein's. However Klein recognised the importance of Hilbert's work and assured him that it would appear in the *Annalen* without any changes whatsoever, as indeed it did.

Hilbert expanded on his methods in a later paper, again submitted to the *Mathematische Annalen* and Klein, after reading the manuscript, wrote to Hilbert saying:- 'I do not doubt that this is the most important work on general algebra that the *Annalen* has ever published.'

In 1893 while still at Königsberg Hilbert began a work *Zahlbericht* on algebraic number theory. The German Mathematical Society requested this major report three years after the Society was created in 1890. The *Zahlbericht* (1897) is a brilliant synthesis of the work of Kummer, Kronecker and Dedekind but contains a wealth of Hilbert's own ideas. The ideas of the present day subject of 'Class field theory' are all contained in this work. Rowe, describes this work as: "... not really a Bericht in the conventional sense of the word, but rather a piece of original research revealing that Hilbert was no mere specialist, however gifted. ... he not only synthesized the results of prior investigations ... but also fashioned new concepts that shaped the course of research on algebraic number theory for many years to come."

Hilbert's work in geometry had the greatest influence in that area after Euclid. A systematic study of the axioms of Euclidean geometry led Hilbert to propose 21 such axioms and he analysed their significance. He published *Grundlagen der Geometrie* in 1899 putting geometry in a formal axiomatic setting. The book continued to appear in new editions and was a major influence in promoting the axiomatic approach to mathematics which has been one of the major characteristics of the subject throughout the 20th century.

Hilbert's famous 23 Paris problems challenged (and still today challenge) mathematicians to solve fundamental questions. Hilbert's famous speech *The Problems of Mathematics* was delivered to the Second International Congress of Mathematicians in Paris. It was a speech full of optimism for mathematics in the coming century and he felt that open problems were the sign of vitality in the subject: "The great importance of definite problems for the progress of mathematical science in general ... is undeniable. ... [for] as long as a branch of knowledge supplies a surplus of such problems, it maintains its vitality. ... every mathematician certainly shares ..the conviction that every mathematical problem is necessarily capable of strict resolution ... we hear within ourselves the constant cry: There is the problem, seek the solution. You can find it through pure thought..."

Hilbert's problems included the continuum hypothesis, the well ordering of the reals, Goldbach's conjecture, the transcendence of powers of algebraic numbers, the Riemann hypothesis, the extension of Dirichlet's principle and many more. Many of the problems were solved during this century, and each time one of the problems was solved it was a major event for mathematics.

Today Hilbert's name is often best remembered through the concept of Hilbert space. Irving Kaplansky, explains Hilbert's work which led to this concept: "Hilbert's work in integral equations in about 1909 led directly to 20th-century research in functional analysis (the branch of mathematics in which functions are studied collectively). This work also established the basis for his work on infinite-dimensional space, later called Hilbert space, a concept that is useful in mathematical analysis and quantum mechanics. Making use of his results on integral equations, Hilbert contributed to the development of mathematical physics by his important memoirs on kinetic gas theory and the theory of radiations. "

In 1934 and 1939 two volumes of *Grundlagen der Mathematik* were published which were intended to lead to a 'proof theory', a direct check for the consistency of mathematics. Gödel's paper of 1931 showed that this aim is impossible.

Hilbert contributed to many branches of mathematics, including invariants, algebraic number fields, functional analysis, integral equations, mathematical physics, and the calculus of variations. Hilbert's mathematical abilities were nicely summed up by Otto Blumenthal, his first student: "In the analysis of mathematical talent one has to differentiate between the ability to create new concepts that generate new types of thought structures and the gift for sensing deeper connections and underlying unity. In Hilbert's case, his greatness lies in an immensely powerful insight that penetrates into the depths of a question. All of his works contain examples from far-flung fields in which only he was able to discern an interrelatedness and connection with the problem at hand. From these, the synthesis, his work of art, was ultimately created. Insofar as the creation of new ideas is concerned, I would place Minkowski higher, and of the classical great ones, Gauss, Galois, and Riemann. But when it comes to penetrating insight, only a few of the very greatest were the equal of Hilbert."

Among Hilbert's students were Weyl and Zermelo.

In 1930 Hilbert retired and the city of Königsberg made him an honorary citizen of the city. He gave an address which ended with six famous words showing his enthusiasm for mathematics and his life devoted to solving mathematical problems:

*"Wir müssen wissen, wir werden wissen"* - *We must know, we shall know.*

## Hilbert's Program

David Hilbert was arguably the most ingenious mathematician of this century. He solved many difficult problems in particular branches of mathematics, and he also was concerned with the foundations of mathematics as a whole. The attempt to give all of mathematics a secure foundation in set theory had foundered on the "paradoxes" of set theory, which were actually presentations of an inherent self-contradiction in the assumptions of set theory. Those assumptions were so intuitively appealing that many great mathematicians, particularly Gottlob Frege, accepted them as a secure starting point from which to develop geometry, algebra, number theory, real analysis, and all other branches of mathematics. The discovery of a contradiction was rather scary to those who cared for the certainty of mathematical reasoning.

Hilbert proposed a program to fix this problem: "I should like to eliminate once and for all the questions regarding the foundations of mathematics, in the form in which they are now posed, by turning every mathematical proposition into a formula that can be concretely exhibited and strictly derived, thus recasting mathematical definitions and inferences in such a way that they are unshakable and yet provide an adequate picture of the whole science." Specifically, Hilbert's program has two parts:

- Provide a single formal system of computation capable of generating all of the true assertions of mathematics from "first principles" (first order logic and elementary set theory).
- Prove mathematically that this system is consistent, that is, that it contains no contradiction. This is essentially a proof of correctness.

If successful, all mathematical questions could be established by mechanical computation

Hilbert's program founded a loosely defined school in the philosophy of mathematics, called *formalism*. Mathematicians of today seem to acknowledge formalism as the basis for their work, but they mostly seem not to understand it. Kurt Gödel showed that Hilbert's program is impossible. But, the clear statement of the program was an immense contribution to our understanding.

## 6 GÖDEL: END OF HILBERTS PROGRAM

Kurt Gödel



Born: 28 April 1906 in Brünn, Austria-Hungary (now Brno, Czech Republic)  
Died: 14 Jan 1978 in Princeton, New Jersey, USA

Kurt Gödel attended school in Brünn, completing his school studies in 1923. His brother Rudolf Gödel said: “Even in High School my brother was somewhat more one-sided than me and to the astonishment of his teachers and fellow pupils had mastered university mathematics by his final Gymnasium years. ... Mathematics and languages ranked well above literature and history. At the time it was rumoured that in the whole of his time at High School not only was his work in Latin always given the top marks but that he had made not a single grammatical error.”

In 1923 Kurt entered the University of Vienna where Furtwängler, Hahn, Wirtinger, Menger, Helly were teachers. As an undergraduate he took part in a seminar run by Schlick which studied Russell's book *Introduction to mathematical philosophy*. Olga Tausky-Todd, a fellow student of Gödel's, wrote: “It became slowly obvious that he would stick with logic, that he was to be Hahn's student and not Schlick's, that he was incredibly talented. His help was much in demand.”

He completed his doctoral dissertation under Hahn's supervision in 1929 and became a member of the faculty of the University of Vienna in 1930, where he belonged to the school of logical positivism until 1938.

He is best known for his proof of Incompleteness Theorems. In 1931 he published these results in *Über formal unentscheidbare Sätze der Principia Mathematica und verwandter Systeme*. He proved fundamental results about axiomatic systems showing in any axiomatic mathematical system there are propositions that cannot be proved or disproved within the axioms of the system. In particular the consistency of the axioms cannot be proved.

This ended a hundred years of attempts to put the whole of mathematics on an axiomatic basis. One major attempt had been by Bertrand Russell with *Principia Mathematica* (1910-13). Another was Hilbert's formalism which suffered a severe blow by Gödel's results.

The theorem did not destroy the fundamental idea of formalism, but it did demonstrate that any system would have to be more comprehensive than that envisaged by Hilbert.

Gödel's results were a landmark in 20th-century mathematics, showing that mathematics is not a finished object, as had been believed. It also implies that a computer can never be programmed to answer all mathematical questions.

Gödel met Zermelo in Bad Elster in 1931. Olga Taussky-Todd, who was at the same meeting, wrote:

‘The trouble with Zermelo was that he felt he had already achieved Gödel's most admired result himself. Scholz seemed to think that this was in fact the case, but he had not announced it and perhaps would never have done so. ... The peaceful meeting between Zermelo and Gödel at Bad Elster was not the start of a scientific friendship between two logicians.’

In 1933 Hitler came to power. At first this had no effect on Gödel's life in Vienna. He had little interest in politics. However after Schlick, whose seminar had aroused Gödel's interest in logic, was murdered by a National Socialist student, Gödel was much affected and had his first breakdown. His brother Rudolf wrote

‘This event was surely the reason why my brother went through a severe nervous crisis for some time, which was of course of great concern, above all for my mother. Soon after his recovery he received the first call to a Guest Professorship in the USA.’

In 1934 Gödel gave a series of lectures at Princeton entitled On undecidable propositions of formal mathematical systems. At Veblen's suggestion Kleene, who had just completed his Ph.D. at Princeton, took notes of these lectures which have been subsequently published.

He returned to Vienna and married Adele Porkert in 1938. In 1940 Gödel emigrated to the United States and held a chair at the Institute for Advanced Study in Princeton, from 1953 to his death. He received the National Medal of Science in 1974.

His work *Consistency of the axiom of choice and of the generalized continuum-hypothesis with the axioms of set theory* (1940) is a classic of modern mathematics.

His brother Rudolf, himself a medical doctor, wrote: “My brother had a very individual and fixed opinion about everything and could hardly be convinced otherwise. Unfortunately he believed all his life that he was always right not only in mathematics but also in medicine, so he was a very difficult patient for doctors. After severe bleeding from a duodenal ulcer ... for the rest of his life he kept to an extremely strict (over strict?) diet which caused him slowly to lose weight.”

Towards the end of his life Gödel became convinced that he was being poisoned and, refusing to eat to avoid being poisoned, starved himself to death.

## 7 TURING: UNIVERSAL AUTOMATON

Alan Mathison Turing



Born: 23 June 1912 in London, England  
Died: 7 June 1954 in Wilmslow, Cheshire, England

Alan Turing's father, Julius Mathison Turing, was a British member of the Indian Civil Service and he was often abroad. Alan's mother, Ethel Sara Stoney, was the daughter of the chief engineer of the Madras railways and Alan's parents had met and married in India. When Alan was about one year old his mother rejoined her husband in India, leaving Alan in England with friends of the family. Alan was sent to school but did not seem to be obtaining any benefit so he was removed from the school after a few months.

Next he was sent to Hazlehurst Preparatory School where he seemed to be an average to good pupil in most subjects but was greatly taken up with following his own ideas. He became interested in chess while at this school and he joined the debating society. He completed his Common Entrance Examination in 1926 and then went to Sherborne School. Now 1926 was the year of the general strike and when the strike was in progress Turing cycled 60 miles to the school from his home, not too demanding a task for Turing who later was to become a fine athlete of almost Olympic standard. He found it very difficult to fit into what was expected at this public school, yet his mother had been so determined that he should have a public school education. Many of the most original thinkers have found conventional schooling an almost incomprehensible process and this seems to have been the case for Turing. His genius drove him in his own directions rather than those required by his teachers.

He was criticised for his handwriting, struggled at English, and even in mathematics he was too interested with his own ideas to produce solutions to problems using the methods taught by his teachers. Despite producing unconventional answers, Turing did win almost every possible mathematics prize while at Sherborne. In chemistry, a subject which had interested him from a very early age, he carried out experiments following his own agenda which did not please his teacher. Turing's headmaster wrote: "If he is to stay at Public School, he must aim at becoming educated. If he is to be solely a Scientific Specialist, he is wasting his time at a Public School."

This says something about the school system that Turing was being subjected to. However, Turing learnt deep mathematics while at school, although his teachers were probably not aware of the studies he was making on his own. He read Einstein's own papers on relativity and he also read about quantum mechanics in Eddington's *The nature of the physical world*.

An event which was to greatly affect Turing throughout his life took place in 1928. He formed a close friendship with Christopher Morcom, a pupil in the year above him at school, and the two worked together on scientific ideas. Perhaps for the first time Turing was able to find someone with whom he could share his thoughts and ideas. However Morcom died in February 1930 and the experience was a shattering one to Turing.

Despite the difficult school years, Turing entered King's College, Cambridge in 1931 to study mathematics. This was not achieved without difficulty. Turing sat the scholarship examinations in 1929 and won an exhibition, but not a scholarship. Not satisfied with this performance, he took the examinations again in the following year, this time winning a scholarship. In many ways Cambridge was a much easier place for unconventional people like Turing than school had been. He was now much more able to explore his own ideas and he read Russell's *Introduction to mathematical philosophy* in 1933. At about the same time he read von Neumann's 1932 text on quantum mechanics, a subject he returned to a number of times throughout his life.

The year 1933 saw the beginnings of Turing's interest in mathematical logic. He read a paper to the Moral Science Club at Cambridge in December of that year of which the following minute was recorded: "A M Turing read a paper on "Mathematics and logic" . He suggested that a purely logistic view of mathematics was inadequate; and that mathematical propositions possessed a variety of interpretations of which the logistic was merely one."

1933 was also the year of Hitler's rise in Germany and of an anti-war movement in Britain. Turing joined the anti-war movement but he did drift neither towards Marxism, nor pacifism, as happened to many.

Turing graduated in 1934 then, in the spring of 1935, he attended Max Newman's advanced course on the foundations of mathematics. This course studied Gödel's incompleteness results and Hilbert's question on decidability. In one sense 'decidability' was a simple question, namely given a mathematical proposition could one find an algorithm which would decide if the proposition was true or false. For many propositions it was easy to find such an algorithm.

The real difficulty arose in proving that for certain propositions no such algorithm existed. When given an algorithm to solve a problem it was clear that it was indeed an algorithm, yet there was no definition of an algorithm which was rigorous enough to allow one to prove that none existed. Turing began to work on these ideas.

Turing was elected a fellow of King's College, Cambridge in 1935 for a dissertation On the Gaussian error function which proved fundamental results on probability theory, namely the central limit theorem. Although the central limit theorem had recently been discovered, Turing was not aware of this and discovered it independently. In 1936 Turing was a Smith's Prizeman.

Turing's achievements at Cambridge had been on account of his work in probability theory. However, he had been working on the decidability questions since attending Newman's course. In 1936 he published *On Computable Numbers, with an application to the Entscheidungsproblem*. It is in this paper that Turing introduced an abstract machine, now called a Turing machine, which moved from one state to another using a precise finite set of rules (given by a finite table) and depending on a single symbol it read from a tape.

### The Turing Machine

The Turing machine could write a symbol on the tape, or delete a symbol from the tape. Turing wrote: "Some of the symbols written down will form the sequences of figures which is the decimal of the real number which is being computed. The others are just rough notes to "assist the memory". It will only be these rough notes which will be liable to erasure. "

He defined *a computable number as real number whose decimal expansion could be produced by a Turing machine starting with a blank tape*. He showed that  $\pi$  was computable, but since only countably many real numbers are computable, *most real numbers are not computable*. He then described a number which is not computable and remarks that this seems to be a paradox since he appears to have described in finite terms. However, Turing understood the source of the apparent paradox. It is impossible to decide (using another Turing machine) whether a Turing machine with a given table of instructions will output an infinite sequence of numbers.

Although this paper contains ideas which have proved of fundamental importance to mathematics and to computer science ever since it appeared, publishing it in the *Proceedings of the London Mathematical Society* did not prove easy. The reason was that Alonzo Church published An unsolvable problem in elementary number theory in the *American Journal of Mathematics* in 1936 which also *proves that there is no decision procedure for arithmetic*. Turing's approach is very different from that of Church but Newman had to argue the case for publication of Turing's paper before the London Mathematical Society would publish it. Turing's revised paper contains a reference to Church's results and the paper, first completed in April 1936, was revised in this way in August 1936 and it appeared in print in 1937.

A good feature of the resulting discussions with Church was that Turing became a graduate student at Princeton University in 1936. At Princeton, Turing undertook research under Church's supervision and he returned to England in 1938, having been back in England for the summer vacation in 1937 when he first met Wittgenstein. The major publication which came out of his work at Princeton was *Systems of Logic Based on Ordinals* which was published in 1939. Newman writes: "This paper is full of interesting suggestions and ideas. ... [it] throws much light on Turing's views on the place of intuition in mathematical proof."

Before this paper appeared, Turing published two other papers on rather more conventional mathematical topics. One of these papers discussed methods of approximating Lie groups by finite groups. The other paper proves results on extensions of groups, which were first proved by Reinhold Baer, giving a simpler and more unified approach.

Perhaps the most remarkable feature of Turing's work on Turing machines was that he was describing a modern computer before technology had reached the point where construction was a realistic proposition. He had proved in his 1936 paper that a universal Turing machine existed: "... which can be made to do the work of any special-purpose machine, that is to say to carry out any piece of computing, if a tape bearing suitable "instructions" is inserted into it."



Although to Turing a "computer" was a person who carried out a computation, we must see in his description of a universal Turing machine what we today think of as a computer with the tape as the program.

While at Princeton Turing had played with the idea of constructing a computer. Once back at Cambridge in 1938 he started to build an analogue mechanical device to investigate the Riemann hypothesis, which many consider today the biggest unsolved problem in mathematics. However, his work would soon take on a new aspect for he was contacted, soon after his return, by the Government Code and Cypher School who asked him to help them in their work on breaking the German Enigma codes.

When war was declared in 1939 Turing immediately moved to work full-time at the Government Code and Cypher School at Bletchley Park. Although the work carried out at Bletchley Park was covered by the Official Secrets Act, much has recently become public knowledge. Turing's brilliant ideas in solving codes, and developing computers to assist break them, may have saved more lives of military personnel in the course of the war than any other. It was also a happy time for him: "... perhaps the happiest of his life, with full scope for his inventiveness, a mild routine to shape the day, and a congenial set of fellow-workers."

Together with another mathematician W G Welchman, Turing developed the Bombe, a machine based on earlier work by Polish mathematicians, which from late 1940 was decoding all messages sent by the Enigma machines of the Luftwaffe. The Enigma machines of the German navy were much harder to break but this was the type of challenge which Turing enjoyed. By the middle of 1941 Turing's statistical approach, together with captured information, had led to the German navy signals being decoded at Bletchley.

From November 1942 until March 1943 Turing was in the United States liaising over decoding issues and also on a speech secrecy system. Changes in the way the Germans encoded their messages had meant that Bletchley lost the ability to decode the messages. Turing was not directly involved with the successful breaking of these more complex codes, but his ideas proved of the greatest importance in this work. Turing was awarded the O.B.E. in 1945 for his vital contribution to the war effort.

At the end of the war Turing was invited by the National Physical Laboratory in London to design a computer. His report proposing the Automatic Computing Engine (ACE) was submitted in March 1946. Turing's design was at that point an original detailed design and prospectus for a computer in the modern sense. The size of storage he planned for the ACE was regarded by most who considered the report as hopelessly over-ambitious and there were delays in the project being approved.

Turing returned to Cambridge for the academic year 1947-48 where his interests ranged over many topics far removed from computers or mathematics, in particular he studied neurology and physiology. He did not forget about computers during this period, however, and he wrote code for programming computers. He had interests outside the academic world too, having taken up athletics seriously after the end of the war. He was a member of Walton Athletic Club winning their 3 mile and 10 mile championship in record time. He ran in the A.A.A. Marathon in 1947 and was placed fifth.

By 1948 Newman was the professor of mathematics at the University of Manchester and offered Turing a readership there. Turing resigned from the National Physical Laboratory to take up the post in Manchester. Newman writes that in Manchester: "... work was beginning on the construction of a computing machine by F C Williams and T Kilburn. The expectation was that Turing would lead the mathematical side of the work, and for a few years he continued to work, first on the design of the subroutines out of which the larger programs for such a machine are built, and then, as this kind of work became standardised, on more general problems of numerical analysis."

In 1950 Turing published *Computing machinery and intelligence in Mind*. It is another remarkable work from his brilliantly inventive mind which seemed to foresee the questions which would arise as computers developed. He studied problems which today lie at the heart of artificial intelligence. It was in this 1950 paper that he proposed the Turing Test which is still today applied. Turing proposed a definition of "thinking" or "consciousness" using the following game: a tester would have to decide, on the basis of written conversation, whether the entity in the next room responding to the tester's queries was a human or a computer. If this distinction could not be made, then it could be fairly said that the computer was "thinking".

Turing did not forget about questions of decidability which had been the starting point for his brilliant mathematical publications. One of the main problems in the theory of group presentations was the question: given any word in a finitely presented group is there an algorithm to decide if the word is equal to the identity. Post had proved that for semigroups no such algorithm exists. Turing thought at first that he had proved the same result for groups but, just before giving a seminar on his proof, he discovered an error. He was able to rescue from his faulty proof the fact that there was a cancellative semigroup with insoluble word problem and he published this result in 1950. Boone used the ideas from this paper by Turing to prove the existence of a group with insoluble word problem in 1957.

Turing was elected a Fellow of the Royal Society of London in 1951, mainly for his work on Turing machines in 1936. By 1951 he was working on the application of mathematical theory to biological forms. In 1952 he published the first part of his theoretical study of morphogenesis, the development of pattern and form in living organisms.

Turing was arrested for violation of British homosexuality statutes in 1952 when he reported to the police details of a homosexual affair. He had gone to the police because he had been threatened with blackmail. He was tried as a homosexual on 31 March 1952, offering no defence other than that he saw no wrong in his actions. Found guilty he was given the alternatives of prison or oestrogen injections for a year. He accepted the latter and returned to a wide range of academic pursuits.

Not only did he press forward with further study of morphogenesis, but he also worked on new ideas in quantum theory, on the representation of elementary particles by spinors, and on relativity theory. Although he was completely open about his sexuality, he had a further unhappiness which he was forbidden to talk about due to the Official Secrets Act.

Turing died of potassium cyanide poisoning while conducting electrolysis experiments. The cyanide was found on a half eaten apple beside him. An inquest concluded that it was self-administered but his mother always maintained that it was an accident.

## 8 VON NEUMANN: COMPUTER

### John von Neumann



Born: 28 Dec 1903 in Budapest, Hungary  
Died: 8 Feb 1957 in Washington D.C., USA

John von Neumann was born János von Neumann. His father, Max Neumann, was a top banker and he was brought up in Budapest where as a child he learnt languages from the German and French governesses. Although the family were Jewish, Max Neumann did not observe the strict practices of that religion and the household seemed to mix Jewish and Christian traditions.

It is also interesting how Max Neumann's son acquired the "von". In 1913 Max Neumann purchased a title but did not change his name. His son, however, used the German form von Neumann.

As a child von Neumann showed he had an incredible memory. He was able to memorize e.g. a page of the phone book, with names, addresses, and numbers in order.

In 1911 von Neumann entered the Lutheran Gymnasium. His mathematics teacher quickly recognised von Neumann's genius and he has obtained special coaching. The school had another outstanding mathematician one year older than von Neumann, namely Eugene Wigner.

After the World War I ended, Béla Kun controlled Hungary for five months in 1919 with a Communist government. The rich came under attack and the Neumann family fled to Austria. However, after a month, they returned to face the problems of Budapest. When Kun's government failed, the fact that it had been largely composed of Jews meant that Jewish people were blamed. Such situations lack logic and the fact that the Neumann's were opposed to Kun's government did not save them from persecution.

In 1921 von Neumann completed his education at the Lutheran Gymnasium. His first mathematics paper written together with Fekete, the assistant at the University of Budapest who had been tutoring him was published in 1922. However Max Neumann wanted his son to follow a career in business, but in the end all agreed on the compromise subject of chemistry for von Neumann's university studies.

Von Neumann studied chemistry at the University of Berlin until 1923 when he went to Zurich. He received his diploma in chemical engineering from the Technische Hochschule in Zürich in 1926. While in Zurich he continued his interest in mathematics, despite studying chemistry, and interacted with Weyl and Pólya who were both at Zurich. He even took over one of Weyl's courses when he was absent from Zurich for a time.

Pólya said “*Johnny was the only student I was ever afraid of. If in the course of a lecture I stated an unsolved problem, the chances were he'd come to me as soon as the lecture was over, with the complete solution in a few scribbles on a slip of paper.*”

Von Neumann received his doctorate in mathematics from the University of Budapest, also in 1926(!), with a thesis on set theory. He published a definition of ordinal numbers when he was 20, the definition is the one used today.

Von Neumann lectured at Berlin from 1926 to 1929 and at Hamburg from 1929 to 1930. He also held a Rockefeller fellowship to enable him to undertake postdoctoral studies at the University of Göttingen. He studied under Hilbert at Göttingen during 1926-27. By this time von Neumann had achieved celebrity status: “*von Neumann's fame had spread worldwide in the mathematical community. At academic conferences, he would find himself pointed out as a young genius.*”

Von Neumann was invited to Princeton to lecture on quantum theory in 1929. He married Marietta Kovesi before setting out for the United States. In 1930 von Neumann became a visiting lecturer at Princeton University, being appointed professor there in 1931.

Between 1930 and 1933 von Neumann taught at Princeton but this was not one of his strong points. “*His fluid line of thought was difficult for those less gifted to follow. He was notorious for dashing out equations on a small portion of the available blackboard and erasing expressions before students could copy them.*”

He became one of the original six mathematics professors (J W Alexander, A Einstein, M Morse, O Veblen, J von Neumann and H Weyl) in 1933 at the newly founded Institute for Advanced Study in Princeton, a position he kept for the remainder of his life.

During the first years that he was in the United States, von Neumann continued to return to Europe during the summers. Until 1933 he still held academic posts in Germany but resigned these when the Nazis came to power.

Von Neumann and Marietta had a daughter Marina in 1936 but their marriage ended in divorce in 1937. The following year he married Klára Dán, also from Budapest, whom he met on one of his European visits. After marrying, they sailed to the United States and made their home in Princeton. There von Neumann lived a rather unusual lifestyle for a top mathematician. He had always enjoyed parties. The parties at the von Neumann's house were frequent, and famous.

In his youthful work, von Neumann was concerned not only with mathematical logic and the axiomatics of set theory, but, simultaneously, with the substance of set theory itself, obtaining interesting results in measure theory and the theory of real variables. It was in this period also that he began his classical work on quantum theory, the mathematical foundation of the theory of measurement in quantum theory and the new statistical mechanics. His text *Mathematische Grundlagen der Quantenmechanik* (1932) built a solid framework for the new quantum mechanics.

In game theory von Neumann proved the minimax theorem. He gradually expanded his work in game theory, and with co-author Oskar Morgenstern, he wrote the classic text *Theory of Games and Economic Behaviour* (1944).

In the middle 30's, Johnny was fascinated by the problem of hydrodynamical turbulence. It was then that he became aware of the mysteries underlying the subject of non-linear partial differential equations. His work, from the beginnings of the Second World War, concerns a study of the equations of hydrodynamics and the theory of shocks. The phenomena described by these non-linear equations are baffling analytically and defy even qualitative insight by present methods. Numerical work seemed to him the most promising way to obtain a feeling for the behaviour of such systems. *This impelled him to study new possibilities of computation on electronic machines ...*

Von Neumann was one of the pioneers of computer science making significant contributions to the development of logical design. Shannon writes: "*Von Neumann spent a considerable part of the last few years of his life working in [automata theory]. It represented for him a synthesis of his early interest in logic and proof theory and his later work, during World War II and after, on large scale electronic computers. Involving a mixture of pure and applied mathematics as well as other sciences, automata theory was an ideal field for von Neumann's wide-ranging intellect. He brought to it many new insights and opened up at least two new directions of research.*"

He advanced the theory of cellular automata, advocated the adoption of the bit as a measurement of computer memory, and solved problems in obtaining reliable answers from unreliable computer components.

During and after World War II, von Neumann served as a consultant to the armed forces. His contributions included a proposal of the implosion method for atomic bombs and his participation in the development of the hydrogen bomb.

## APPENDIX 1

### Charles Babbage



Born: 26 Dec 1791 in London, England  
Died: 18 Oct 1871 in London, England

Charles Babbage's father was Benjamin Babbage, a banker, and his mother was Betsy Plumleigh Babbage.

Charles suffered ill health as a child, as he relates: “Having suffered in health at the age of five years, and again at that of ten by violent fevers, from which I was with difficulty saved, I was sent into Devonshire and placed under the care of a clergyman (who kept a school at Alphington, near Exeter), with instructions to attend to my health; but, not to press too much knowledge upon me: a mission which he faithfully accomplished. “

Since his father was fairly wealthy, he could afford to have Babbage educated at private schools. After the school at Alphington he was sent to an academy at Forty Hill, Enfield, Middlesex where his education properly began. He began to show a passion for mathematics but a dislike for the classics. On leaving the academy, he continued to study at home, having an Oxford tutor to bring him up to university level.

Babbage entered Trinity College, Cambridge in 1810. However the grounding he had acquired from the books he had studied made him dissatisfied with the teaching at Cambridge. He wrote: “*Thus it happened that when I went to Cambridge I could work out such questions as the very moderate amount of mathematics which I then possessed admitted, with equal facility, in the dots of Newton, the d's of Leibniz, or the dashes of Lagrange. I thus acquired a distaste for the routine of the studies of the place, and devoured the papers of Euler and other mathematicians scattered through innumerable volumes of the academies of St Petersburg, Berlin, and Paris, which the libraries I had recourse to contained. Under these circumstances it was not surprising that I should perceive and be penetrated with the superior power of the notation of Leibniz.*”

Babbage and Herschel produced the first of the publications of the Analytical Society when they published *Memoirs of the Analytical Society* in 1813. This is a remarkably deep work when one realises that it was written by two undergraduates.

Babbage had moved from Trinity College to Peterhouse and it was from that College that he graduated with a B.A. in 1814.

Babbage married in 1814, then left Cambridge in 1815 to live in London. He wrote two major papers on functional equations in 1815 and 1816. Also in 1816, at the early age of 24, he was elected a fellow of the Royal Society of London.

Babbage was discontented with the way that the learned societies of that time were run. Although elected to the Royal Society of London, he was unhappy with it. He was to write of his feelings on how the Royal Society was run: *“The Council of the Royal Society is a collection of men who elect each other to office and then dine together at the expense of this society to praise each other over wine and give each other medals. ”*

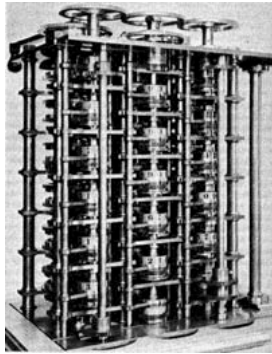

Figure 1 Babbage's Differential Engine

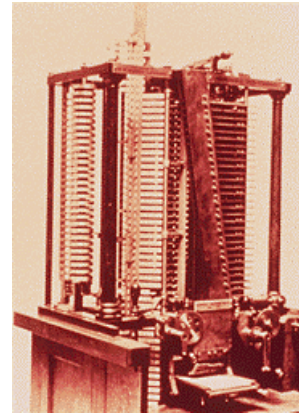

Figure 2 Babbage's Analytical Engine

In 1827 Babbage became Lucasian Professor of Mathematics at Cambridge, a position he held for 12 years although he never taught. He was completely absorbed in what was to become the main passion of his life, namely the development of mechanical computers.

The computation of logarithms had made Babbage aware of the inaccuracy of human calculation around 1812. He wrote: *...“I am thinking that all these tables (logarithms) might be calculated by machinery. ”*

In 1819, when his interests were turning towards astronomical instruments, Babbage's ideas became more precise and he formulated a plan to construct tables using the method of differences by mechanical means. Such a machine would be able to carry out complex operations using only the mechanism for addition.

Babbage began to construct a small difference engine in 1819. He published his invention in a paper *Note on the application of machinery to the computation of astronomical and mathematical tables* read to the Royal Astronomical Society in 1822.

His initial grant was for 1500 and he began work on a large difference engine which he believed he could complete in three years. He set out to produce an engine with *“... six orders of differences, each of twenty places of figures, whilst the first three columns would each have had half a dozen additional figures. ”*

Such an engine would easily have been able to compute all the logarithm tables, and it was intended to have a printer to print out the results automatically. However the construction proceeded slower than expected. By 1827 the expenses were getting out of hand.

The year 1827 was a year of tragedy for Babbage; his father, his wife and two of his children all died that year. His own health was poor and he was advised to travel on the Continent. After his travels he returned near the end of 1828.

Further attempts to obtain government support eventually resulted in the Duke of Wellington, the Chancellor of the Exchequer and other members of the government visiting Babbage and inspecting the work. By February 1830 the government had paid, or promised to pay, 9000 towards the project.

In 1830 Babbage published *Reflections on the Decline of Science in England*, a controversial work that resulted in the formation, one year later, of the British Association for the Advancement of Science. In 1834 Babbage published his most influential work *On the Economy of Machinery and Manufactures*, in which he proposed an early form of what today we call operational research.

The year 1834 was the one in which work stopped on the difference engine. By that time the government had put 17000 into the project and Babbage had put 6000 of his own money. For eight years from 1834 to 1842 the government would make no decision as to whether to continue support. In 1842 the decision not to proceed was taken by Robert Peel's government. Dubbey writes: "*Babbage had every reason to feel aggrieved about his treatment by successive governments. They had failed to understand the immense possibilities of his work, ignored the advice of the most reputable scientists and engineers, procrastinated for eight years before reaching a decision about the difference engine, misunderstood his motives and the sacrifices he had made, and ... failed to protect him from public slander and ridicule.*"

By 1834 Babbage had completed the first drawings of the *analytical engine*, the forerunner of the modern electronic computer. His work on the difference engine had led him to a much more sophisticated idea. Although the analytic engine never progressed beyond detailed drawings, it is remarkably similar in logical components to a present day computer.

Babbage describes five logical components, the store, the mill, the control, the input and the output. The store contains "... *all the variables to be operated upon, as well as all those quantities which had arisen from the results of other operations.*"

The mill is the analogue of the CPU in a modern computer and it is the place: "... *into which the quantities about to be operated upon are always brought.*"

The control on the sequence of operations to be carried out was by a Jacquard loom type device. It was operated by punched cards and the punched cards contained the program for the particular task: "*Every set of cards made for any formula will at any future time recalculate the formula with whatever constants may be required. Thus the Analytical Engine will possess a library of its own. Every set of cards once made will at any time reproduce the calculations for which it was first arranged.*"

The store was to hold 1000 numbers each of 50 digits, but Babbage designed the analytic engine to effectively have infinite storage. This was done by outputting data to punched cards which could be read in again at a later stage when needed. Babbage decided, however, not to seek government support after his experiences with the difference engine.

Babbage visited Turin in 1840 and discussed his ideas with mathematicians there including Menabrea who collected all the material needed to describe the analytical engine and published this in 1842. Lady Ada Lovelace translated Menabrea's article into English and added notes considerably more extensive than the original account. This was published in 1843 and included: "... *elaborations on the points made by Menabrea, together with some*



*complicated programs of her own, the most complex of these being one to calculate the sequence of Bernoulli numbers”*

Although Babbage never built an operational, mechanical computer, his design concepts have been proved correct and recently such a computer has been built following Babbage's own design criteria.

Babbage never did quite give up hope that the analytical engine would be built writing in 1864: *”... if I survive some few years longer, the Analytical Engine will exist...”*

After Babbage's death a committee , was appointed by the British Association: *“... to report upon the feasibility of the design, recorded their opinion that its successful realization might mark an epoch in the history of computation equally memorable with that of the introduction of logarithms...”*

This was an understatement. Modern computers, logically similar to Babbage's, have changed the mathematics. We can say that they have changed the whole world.

### **Augusta Ada King, Countess of Lovelace**



Born: 10 Dec 1815 in Piccadilly, Middlesex (now in London), England  
Died: 27 Nov 1852 in Marylebone, London, England

Augusta Ada Byron was the daughter of poet Lord Byron. Five weeks after Ada was born Lady Byron asked for a separation from Lord Byron, and was awarded sole custody of Ada who she brought up to be a mathematician and scientist. She was educated by private tutors. Advanced study in mathematics are being provided by De Morgan. She became Countess of Lovelace when her husband William King, whom she married in 1835, was created an Earl in 1838.

In 1833 Lady Lovelace became interested in Babbage's analytic engine. Ten years later she produced an annotated translation of Menabrea's *Notions sur la machine analytique de Charles Babbage* (1842). In the annotations she describes how the Analytical Engine could be programmed to compute Bernoulli numbers.

Lady Lovelace's prophetic comments included her predictions that such a machine might be used to compose complex music, to produce graphics, and would be used for both practical and scientific use. She was correct.

She described the Analytical Engine in very famous words: *“the Analytical Engine weaves algebraic patterns, just as the Jacquard-loom weaves flowers and leaves.”*

## APPENDIX 2

### Russels paradox

Russell discovered the paradox which bears his name in 1901, while working on his *Principles of Mathematics*.

The paradox occurred in connection with the set of all sets which are not members of themselves. *Such a set, if it exists, will be a member of itself if and only if it is not a member of itself.*

The significance of the paradox follows since, in classical logic, all sentences are affected by a contradiction. In the eyes of many mathematicians (including David Hilbert) it therefore appeared that no proof could be trusted once it was *discovered that the logic apparently underlying all of mathematics was contradictory.*

Russell's paradox arises as a result of *unrestricted comprehension (or abstraction) axiom* of naive set theory. Originally introduced by Georg Cantor, the axiom states that: *any predicate expression,  $P(x)$ , which contains  $x$  as a free variable, will determine a set whose members are exactly those objects which satisfy  $P(x)$ .*

The axiom gives form to the intuition that any coherent condition may be used to determine a set (or class). Most attempts at resolving Russell's paradox have therefore concentrated on various ways of restricting or abandoning this axiom.

Russell's own response to the paradox came with the introduction of his theory of types. His basic idea was that reference to troublesome sets (such as the set of all sets which are not members of themselves) could be avoided by *arranging all sentences into a hierarchy (beginning with sentences about individuals at the lowest level, sentences about sets of individuals at the next lowest level, sentences about sets of sets of individuals at the next lowest level, etc.).*

Using the vicious circle principle also adopted by Henri Poincaré, together with his so-called "no class" theory of classes, Russell was then able to explain why the unrestricted comprehension axiom fails. *Propositional functions, such as the function "x is a set", should not be applied to themselves since self-application would involve a vicious circle.*

On this view, it follows that it is possible to refer to a collection of objects for which a given condition (or predicate) holds only if they are all at the same level or of the same "type".

Although first introduced by Russell in 1903 in the *Principles*, his theory of types finds its mature expression in his 1908 article *Mathematical Logic as Based on the Theory of Types* and in the monumental work he co-authored with Alfred North Whitehead, *Principia Mathematica* (1910, 1912, 1913). Thus, in its details, the theory admits of two versions, the "simple theory" and the "ramified theory".